



US008405161B2

(12) **United States Patent**
Park et al.

(10) **Patent No.:** **US 8,405,161 B2**
(45) **Date of Patent:** **Mar. 26, 2013**

(54) **DRIVING DEVICE FOR UNIT PIXEL OF ORGANIC LIGHT EMITTING DISPLAY AND METHOD OF MANUFACTURING THE SAME**

(75) Inventors: **Kyung-bae Park**, Yongin-si (KR);
Jang-yeon Kwon, Yongin-si (KR);
Sang-yoon Lee, Yongin-si (KR); **Ji-sim Jung**, Yongin-si (KR)

(73) Assignee: **Samsung Electronics Co., Ltd.** (KR)

(*) Notice: Subject to any disclaimer, the term of this patent is extended or adjusted under 35 U.S.C. 154(b) by 470 days.

(21) Appl. No.: **11/877,308**

(22) Filed: **Oct. 23, 2007**

(65) **Prior Publication Data**
US 2008/0116457 A1 May 22, 2008

(30) **Foreign Application Priority Data**
Nov. 22, 2006 (KR) 10-2006-0116057

(51) **Int. Cl.**
H01L 27/088 (2006.01)
(52) **U.S. Cl.** **257/401**; 257/66; 349/199
(58) **Field of Classification Search** 257/401,
257/66, E27.006; 349/199
See application file for complete search history.

(56) **References Cited**

U.S. PATENT DOCUMENTS

5,372,959	A *	12/1994	Chan	438/157
6,291,863	B1 *	9/2001	Chan	257/401
6,714,178	B2 *	3/2004	Koyama et al.	345/76
7,312,568	B2 *	12/2007	Park	313/504
7,425,749	B2 *	9/2008	Hartzell et al.	257/414

FOREIGN PATENT DOCUMENTS

JP	2002-033481	A	1/2002
JP	2003-223120	A	8/2003
JP	2006-178031	A	7/2006
KR	1020040060473	A	7/2004
KR	1020060059582	A	6/2006
KR	1020060060937	A	6/2006

OTHER PUBLICATIONS

Korean Office Action with English Translation for Application No. 10-2006-0116057 dated Jul. 13, 2012.

* cited by examiner

Primary Examiner — Howard Weiss
Assistant Examiner — Steven Rao

(74) *Attorney, Agent, or Firm* — Cantor Colburn LLP

(57) **ABSTRACT**

Provided are a driving device for a unit pixel of an organic light emitting display having an improved structure and a method of manufacturing the same.

16 Claims, 15 Drawing Sheets

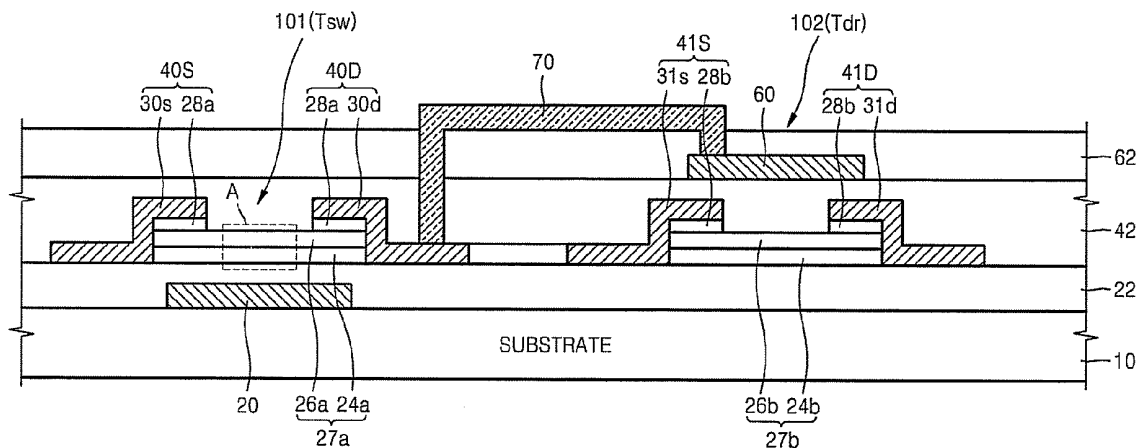

FIG. 1

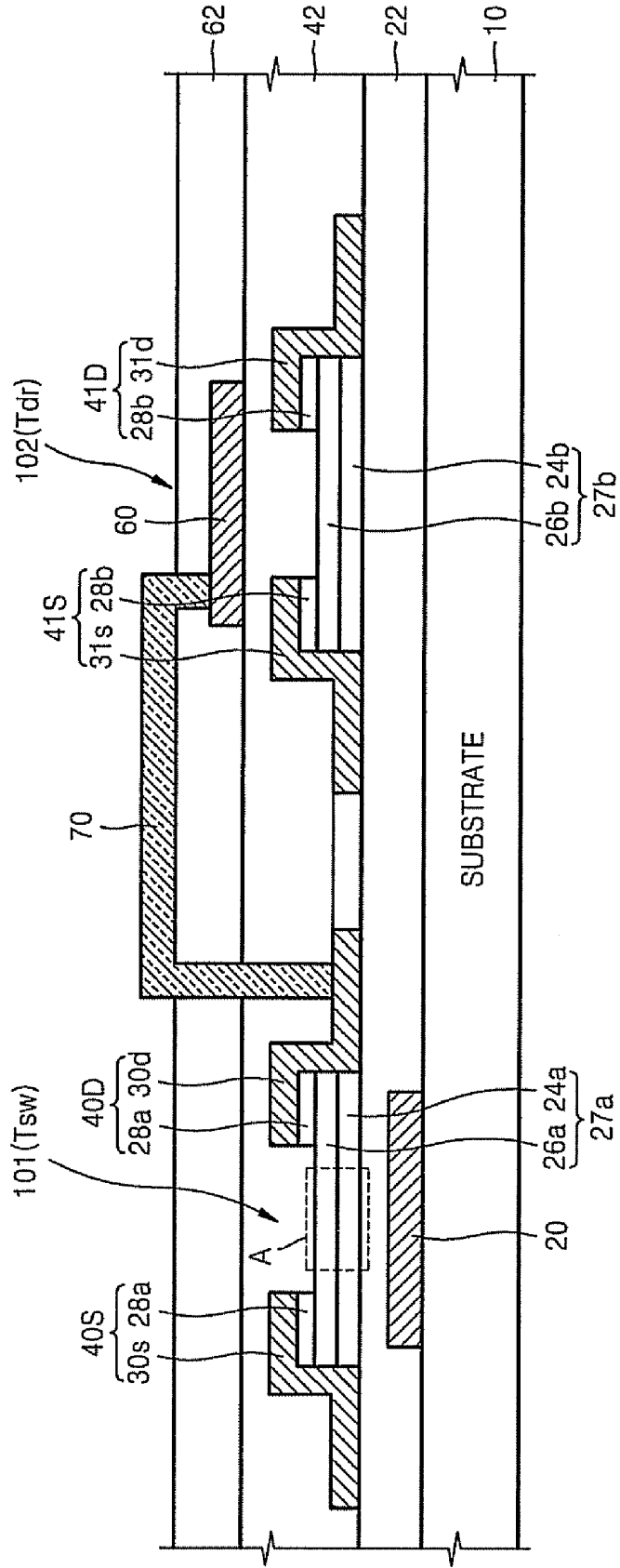

FIG. 2

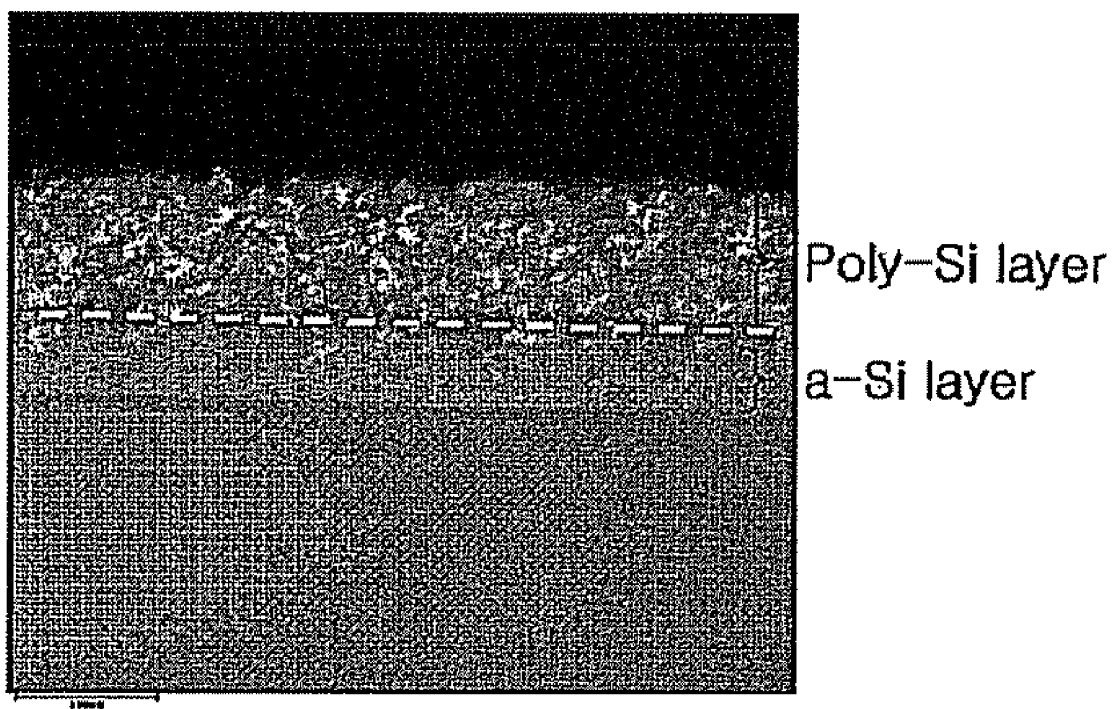

FIG. 3A

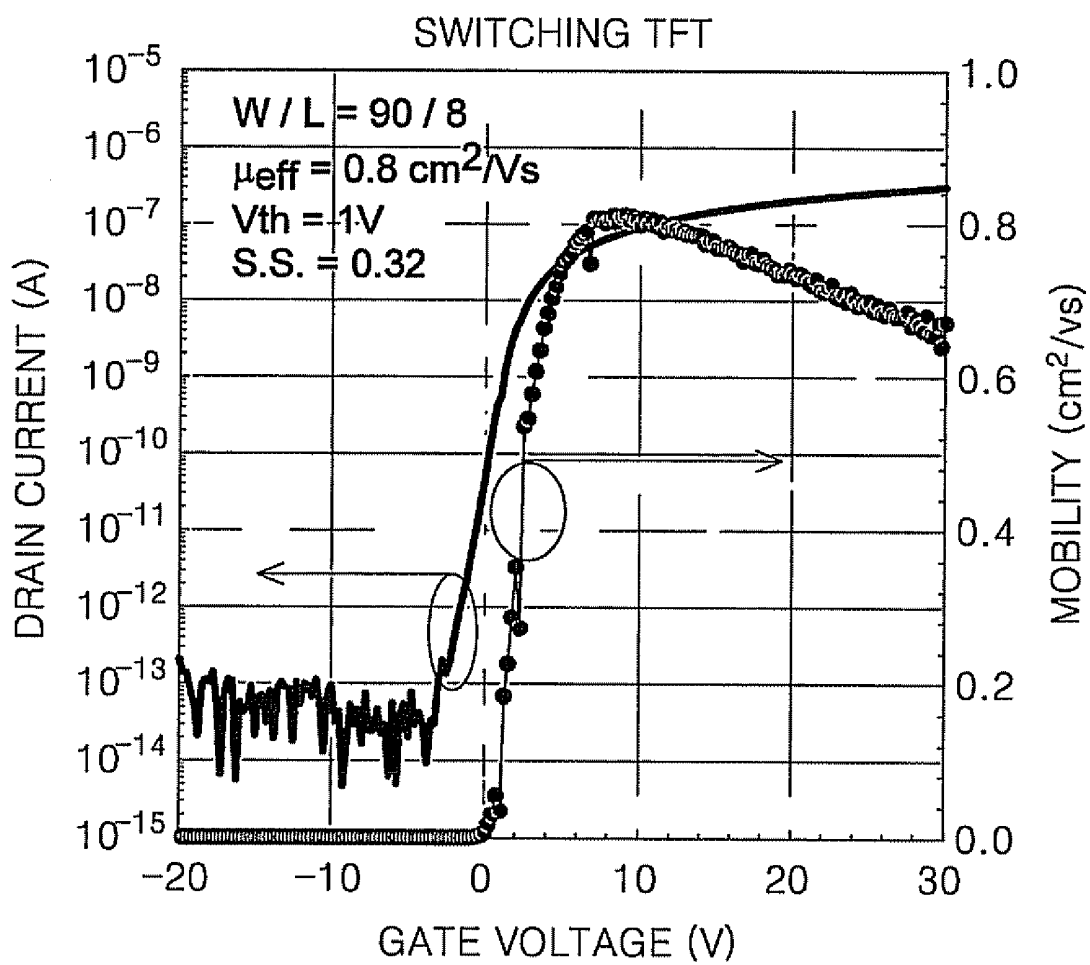

FIG. 3B

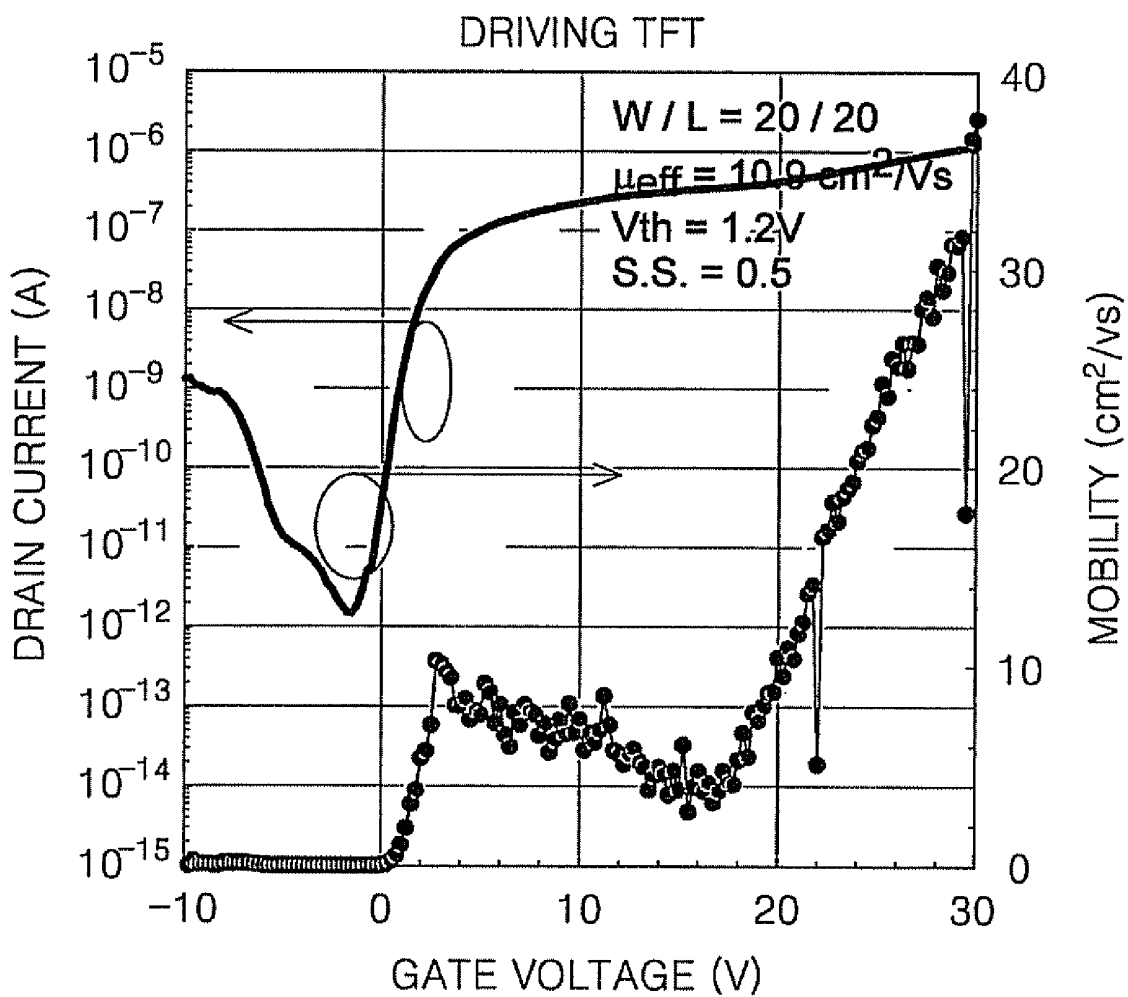

FIG. 4A

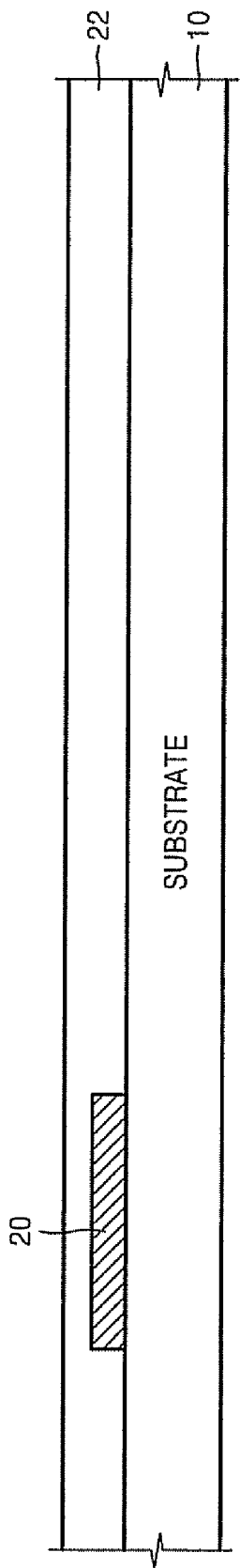

FIG. 4B

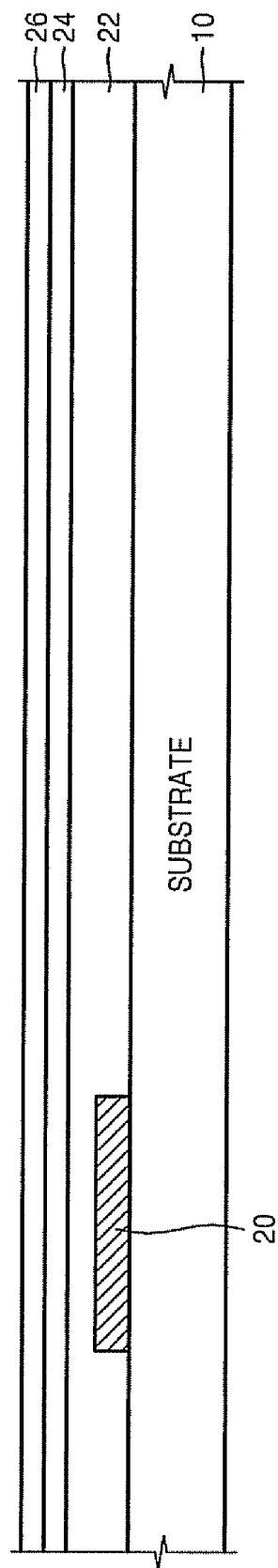

FIG. 4C

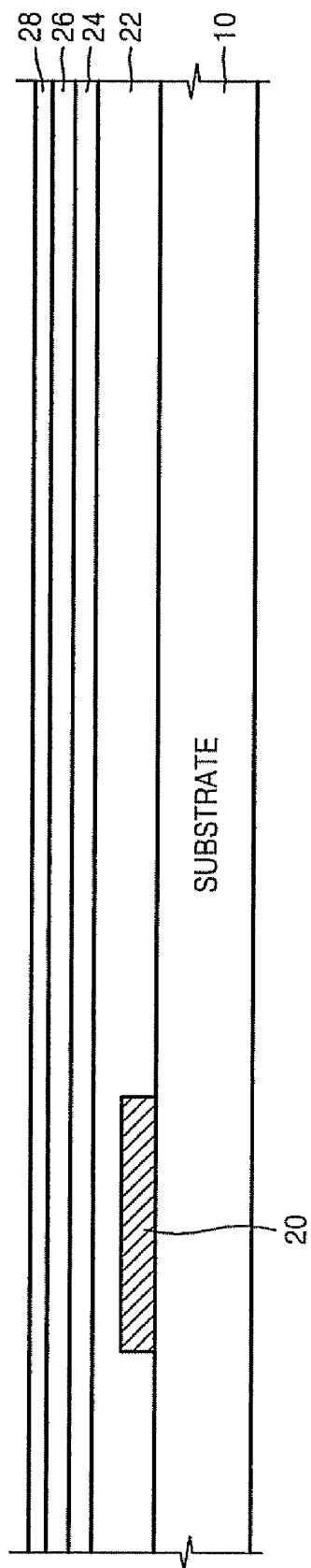

FIG. 4D

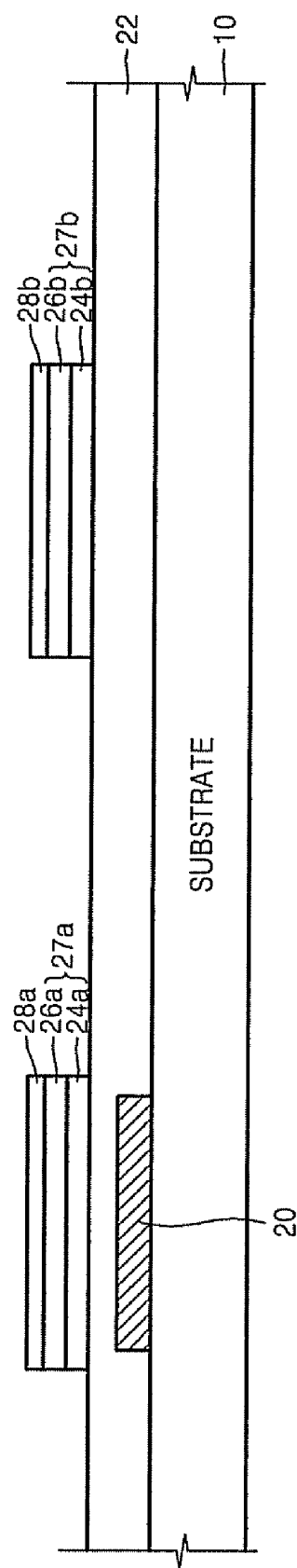

FIG. 4E

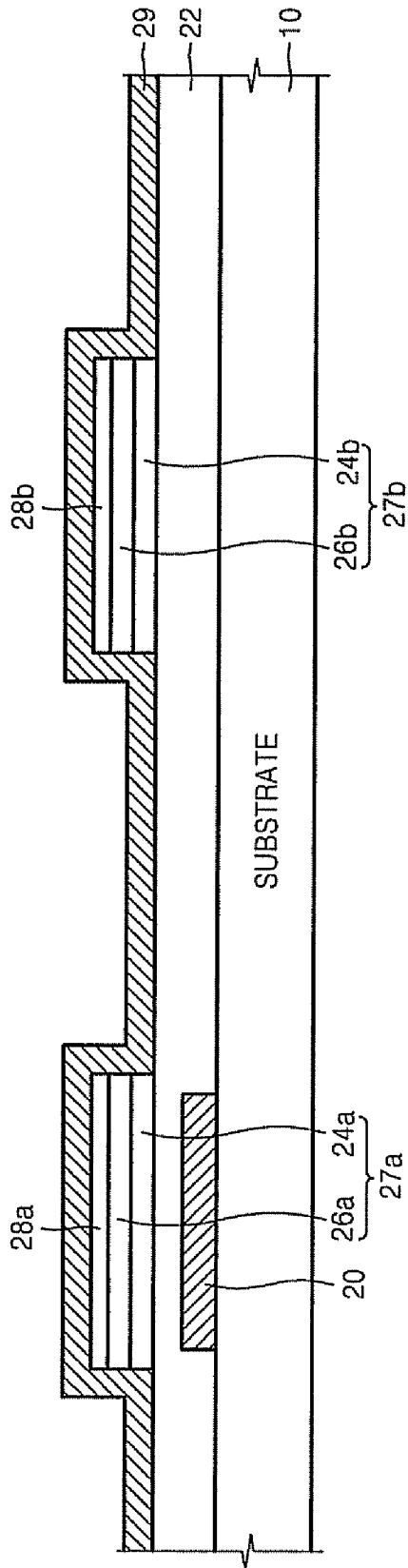

FIG. 4F

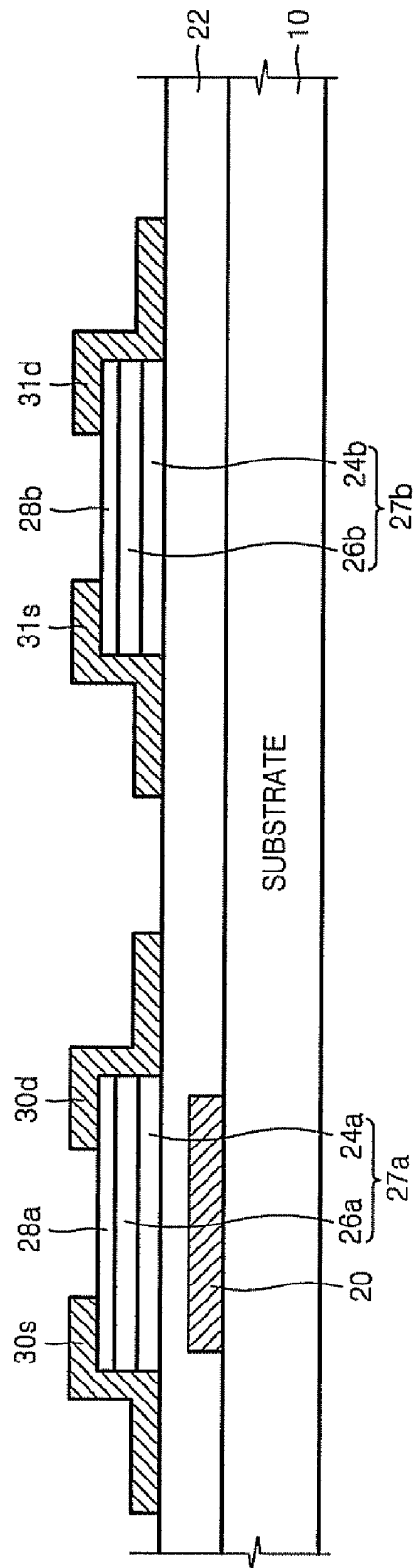

FIG. 4G

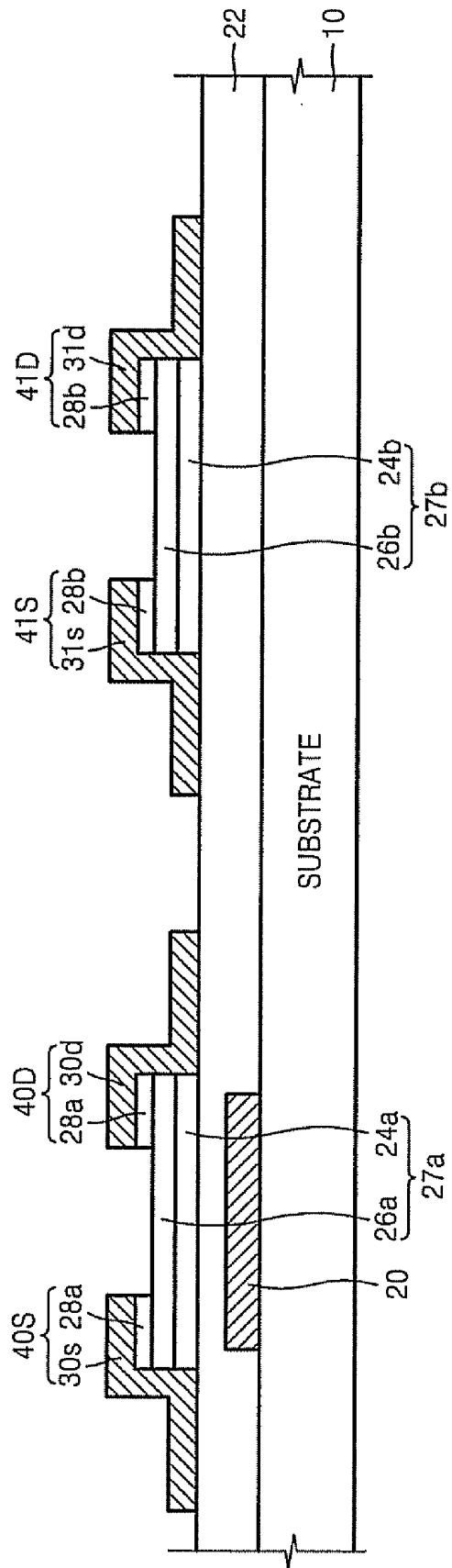

FIG. 4H

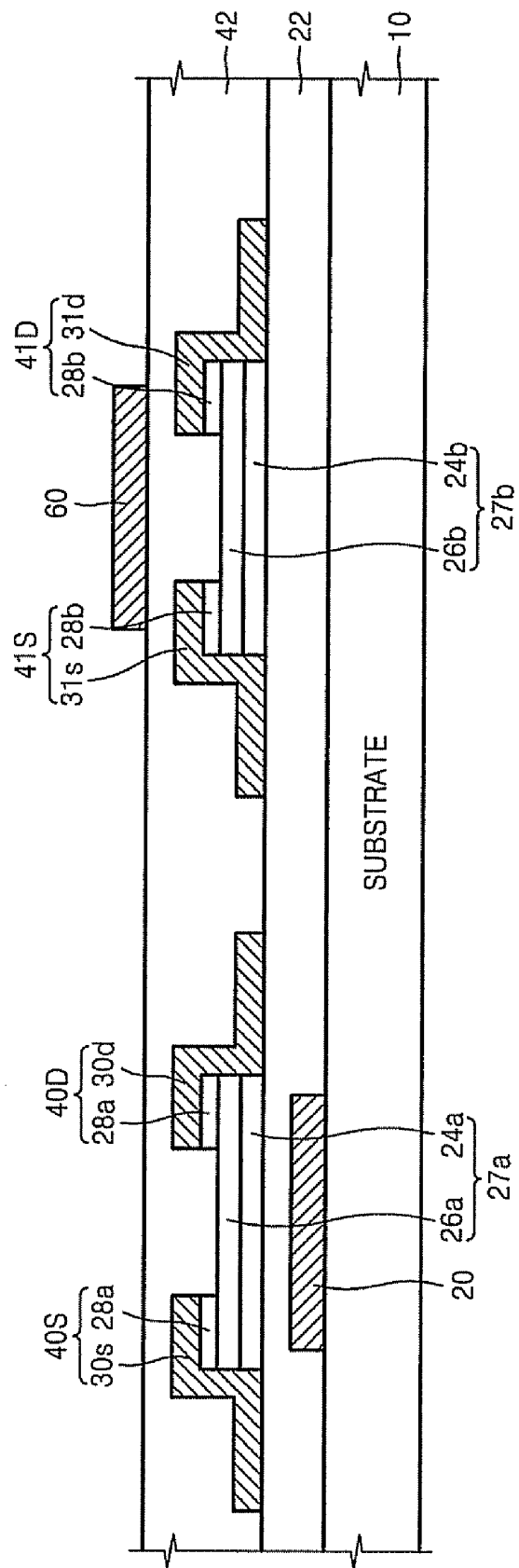

FIG. 4I

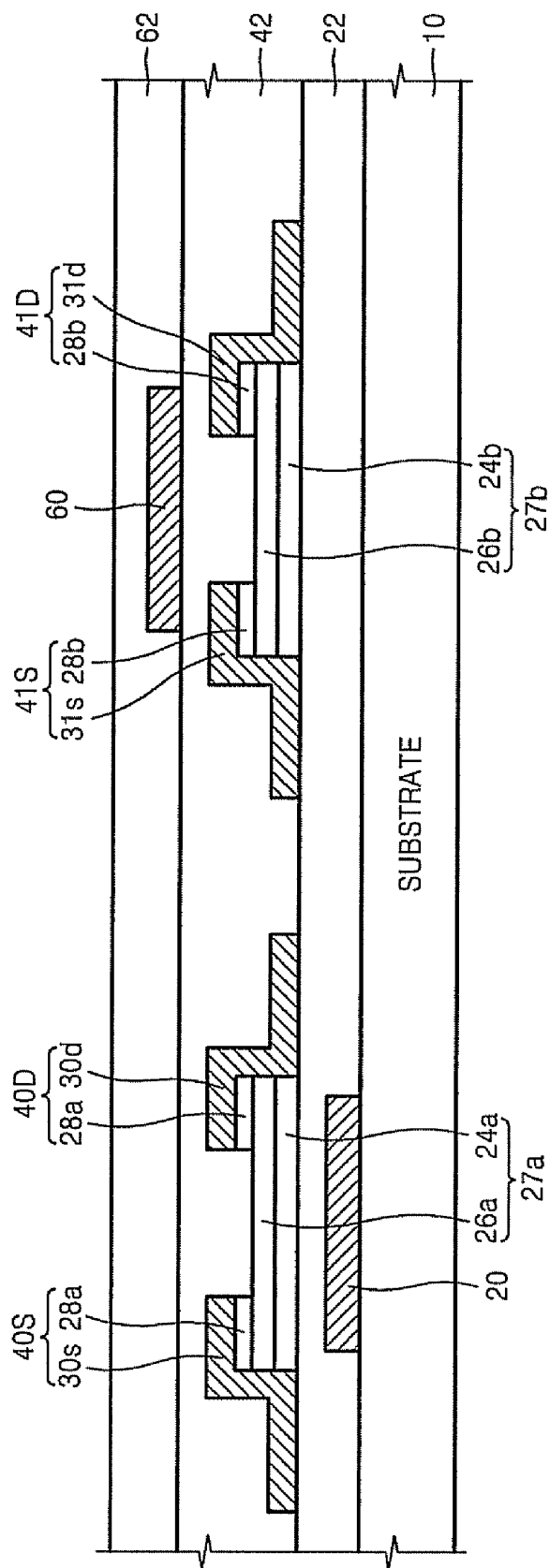

FIG. 4J

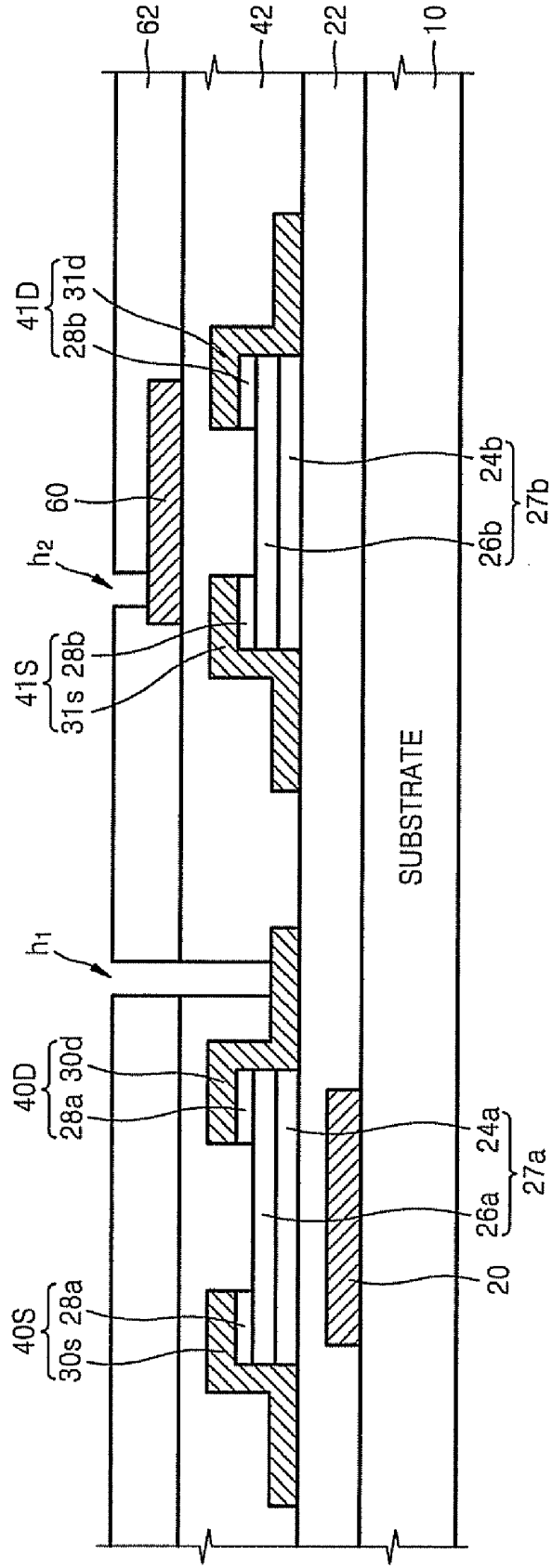

FIG. 4K

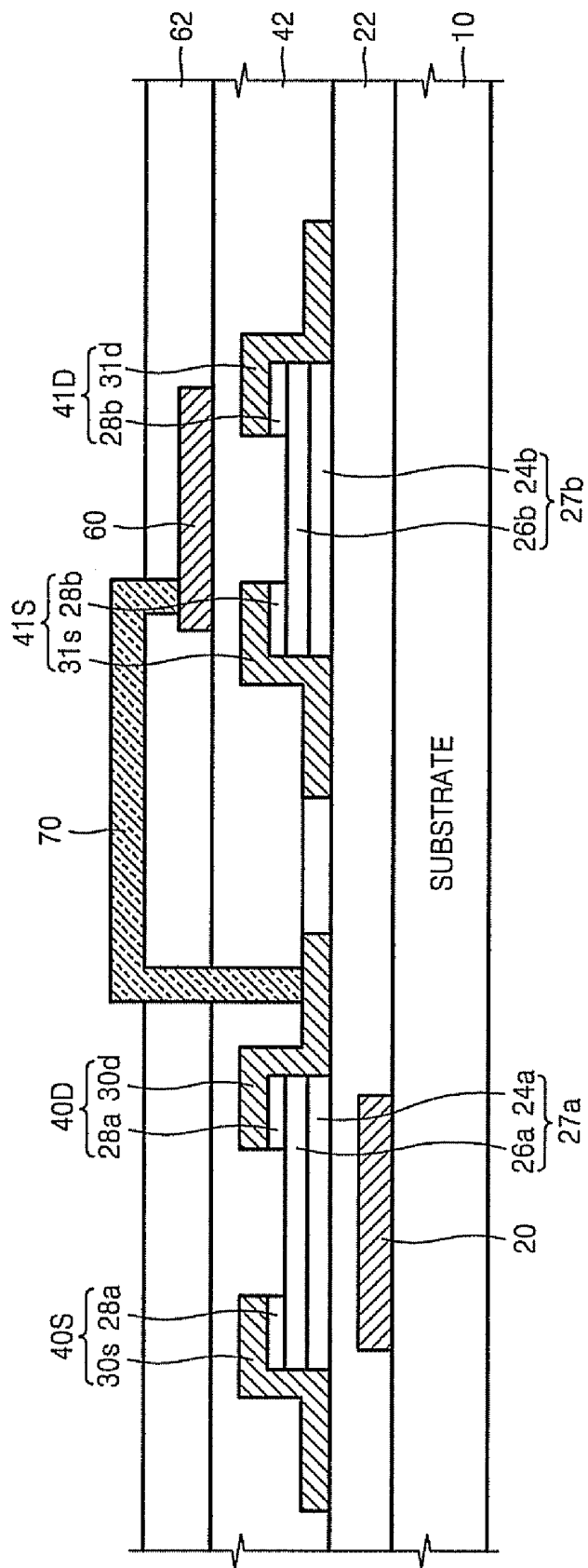

FIG. 5

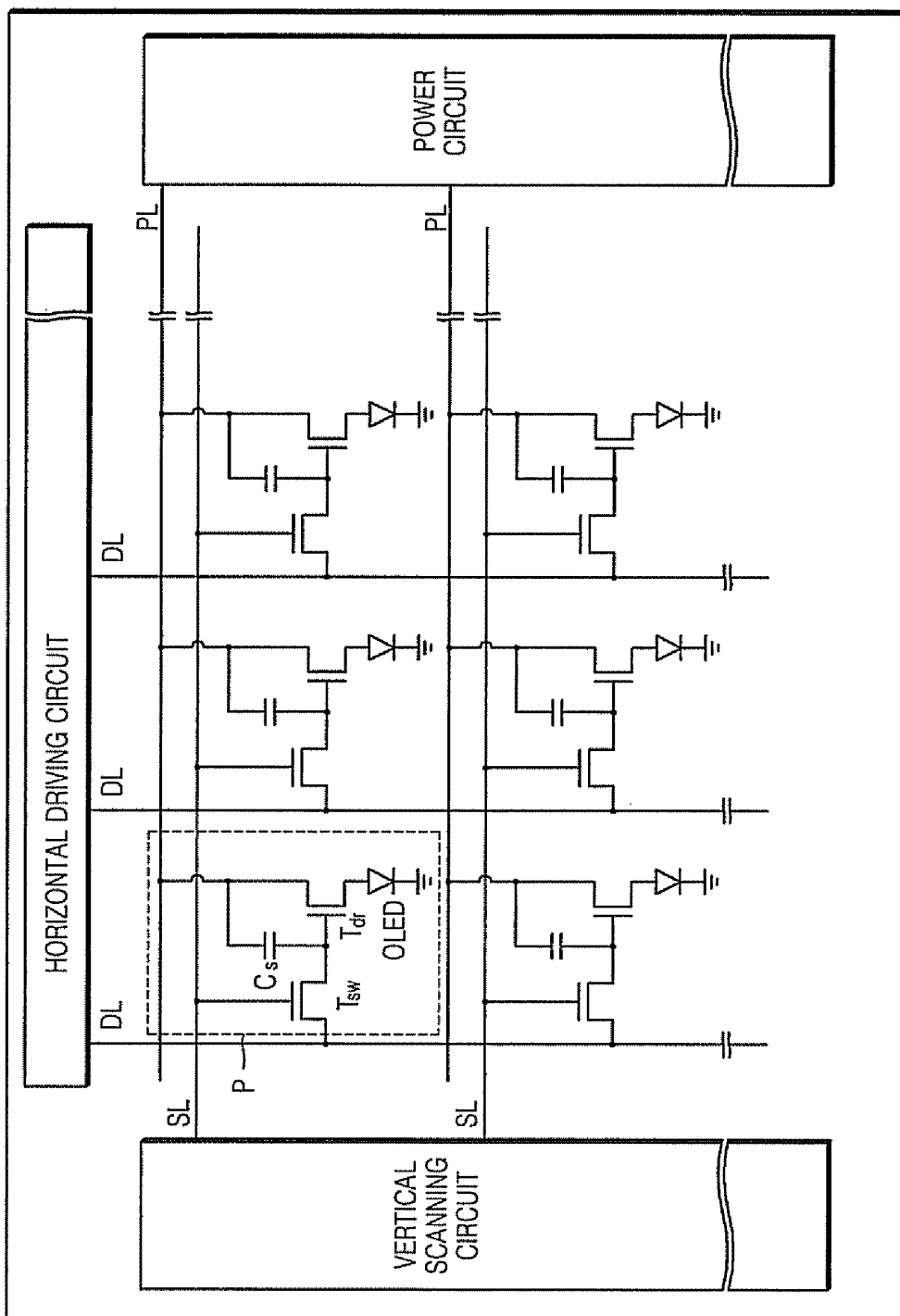
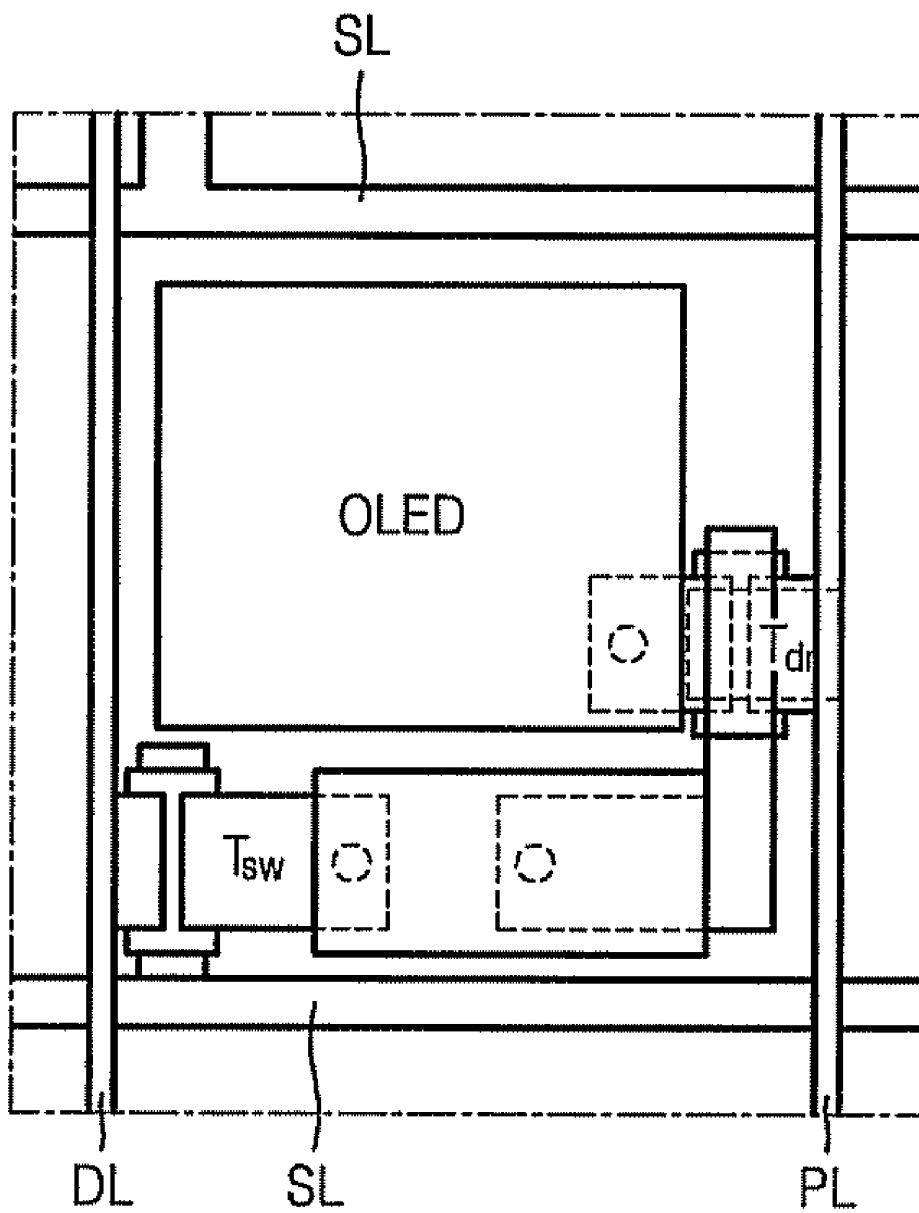

FIG. 7



**DRIVING DEVICE FOR UNIT PIXEL OF
ORGANIC LIGHT EMITTING DISPLAY AND
METHOD OF MANUFACTURING THE SAME**

CROSS-REFERENCE TO RELATED PATENT
APPLICATIONS

This application claims priority to Korean Patent Application No. 10-2006-0116057, filed on Nov. 22, 2006, and all the benefits accruing therefrom under 35 U.S.C. §119, the contents of which are incorporated herein by reference in their entirety.

BACKGROUND OF THE INVENTION

1. Field of the Invention

Disclosed herein is a driving device for a unit pixel of an organic light emitting display, and more specifically, to a driving device for a unit pixel of an OLED having an improved structure in which the driving device can be more easily manufactured.

2. Description of the Related Art

Liquid crystal displays (LCDs), because they are not heavy and have low power consumption, are desirable for use in flat panel displays (FPDs). However, since LCDs are light-receiving type displays, it can be difficult to meet technical specifications for brightness, contrast, view angle, as well as use in larger sized displays. Development for new FPDs that can overcome these disadvantages has proceeded rapidly. Organic light emitting displays (OLEDs), a new possibility for use with FPDs, have a two-dimensional arrangement and self light-emitting pixels. Thus, OLEDs have excellent characteristics, such as excellent view angle and contrast. It is highly desirable that OLEDs do not need backlights, as are needed with LCDs. Thus, OLEDs can be made even lighter and smaller and have very low power consumption. In addition, since OLEDs can be directly driven by low voltages, have a fast response speed, and are entirely solid bodies, the OLEDs tend to be resistant to external shocks, and can be used in a wide temperature range. Also highly desirable is that the OLEDs have low manufacturing costs. Specifically, if OLEDs are driven using an active matrix method by which transistors as switching devices are disposed in each pixel, the OLEDs show the same brightness even if low currents are applied to the OLEDs. Thus, the OLEDs require less power, have high definition, and can be utilized in large FPDs.

Two thin film transistors (TFTs), a switching TFT and a driving TFT, can be provided in each unit pixel of the active matrix type OLEDs, so as to drive an OLED. The switching TFT turns on/off a current supplied to each unit pixel, and the driving TFT provides currents allocated to the OLED. Due to this role assignment, characteristics and specifications of the switching TFT and driving TFT are different. For example, the switching TFT can have a small leakage current and a large on/off ratio. On the other hand, the driving TFT is required to have high mobility and reliability. In order to meet the requirements, the switching TFT can be formed as an amorphous silicon TFT and the driving TFT can be formed as a polycrystalline silicon transistor.

However, the process of manufacturing the switching TFT and the process of manufacturing the driving TFT are separately performed. This results in increased manufacturing complexity, which increases costs. Meanwhile, when an amorphous silicon TFT is simultaneously used as the switching TFT and the driving TFT, the amorphous silicon TFT is worthy of a switching TFT, but low electron mobility and reliability hinder practical applicability. Thus, it is difficult to

implement an OLED having excellent characteristics. Contrary to this, when a polycrystalline silicon TFT is used as a switching TFT, the polycrystalline silicon TFT is worthy of a driving TFT, but a large leakage current in the off-state hinders practical applicability. Thus, the possibility of use of the polycrystalline silicon TFT as a switching transistor is reduced.

SUMMARY OF THE INVENTION

Disclosed herein is a driving device for a unit pixel of an OLED having an improved structure in which the driving device can be manufactured with a smaller number of processes and in simpler and easier processes. Disclosed too is a method of manufacturing the same.

In one embodiment, there is provided a driving device for a unit pixel of an OLED, the driving device for a unit pixel comprising: a pair of a switching thin film transistor (TFT) and a driving TFT, which are formed on a substrate and in communication with each other, wherein the switching TFT is formed in a bottom gate structure, the bottom gate structure comprising a first dual channel layer having a first amorphous silicon layer and a first polycrystalline silicon layer, and a first gate electrode formed below the first dual channel layer and facing the first amorphous silicon layer, and the driving TFT is formed in a top gate structure, the top gate structure comprising a second dual channel layer having a second amorphous silicon layer and a second polycrystalline silicon layer, and a second gate electrode formed above the second dual channel layer and facing the second amorphous silicon layer.

In another embodiment, there is provided a method of manufacturing a driving device for a unit pixel of an OLED comprising a switching TFT and driving TFT that are formed on a substrate and are in electrical communication with each other. The method comprises forming the switching TFT in a bottom gate structure, the bottom gate structure comprising a first dual channel layer having a first amorphous silicon layer and a first polycrystalline silicon layer, and a first gate electrode formed below the first dual channel layer and facing the first amorphous silicon layer; and forming the driving TFT in a top gate structure, the top gate structure comprising a second dual channel layer having a second amorphous silicon layer and a second polycrystalline silicon layer, and a second gate electrode formed above the second dual channel layer and facing the second amorphous silicon layer, wherein the first dual channel layer and the second dual channel layer are simultaneously formed in one process.

The forming of the switching TFT can comprise: forming a first gate electrode on a substrate; forming a first insulating layer that covers the first gate electrode on the substrate; forming a first dual channel layer that comprises a first amorphous silicon layer and first polycrystalline silicon layer on the first insulating layer; and forming a first source region and a first drain region at opposite ends of the first dual channel layer, respectively.

The forming of the driving TFT can comprise: forming a second dual channel layer on the first insulating layer to be separated from the first dual channel layer, the second dual channel layer comprising a second amorphous silicon layer and second polycrystalline silicon layer; forming a second source region and a second drain region at opposite ends of the second dual channel layer, respectively; forming a second insulating layer that covers the second dual channel layer, the second source region, and the second drain region; and forming a second gate electrode on the second insulating layer to face the second polycrystalline silicon layer.

In another embodiment, there is provided an OLED comprising a plurality of unit pixels disposed on a substrate in a matrix shape, wherein each of the unit pixels comprises: a driving device for a unit pixel comprising a switching TFT and driving TFT that are in electrical communication with each other; and an OLED for a unit pixel, wherein the switching TFT is formed in a bottom gate structure, the bottom gate structure comprising a first dual channel layer having a first amorphous silicon layer and a first polycrystalline silicon layer, and a first gate electrode formed below the first dual channel layer and facing the first amorphous silicon layer, and the driving TFT is formed in a top gate structure, the top gate structure comprising a second dual channel layer having a second amorphous silicon layer and a second polycrystalline silicon layer, and a second gate electrode formed above the second dual channel layer and facing the second amorphous silicon layer.

In one embodiment, the OLED and the method of manufacturing the same have been improved so that channels in a switching TFT and a driving TFT can be simultaneously formed in one process. As a result, the driving device for a unit pixel of an OLED disclosed herein can be manufactured in a smaller number of processes and in simpler and easier processes compared to the prior art.

BRIEF DESCRIPTION OF THE DRAWINGS

The above and other features and advantages will become more apparent by describing in detail exemplary embodiments thereof with reference to the attached drawings in which:

FIG. 1 is a schematic cross-sectional view of a driving device for a unit pixel of an OLED.

FIG. 2 is a cross-sectional scanning electronic microscope (SEM) photo of a first dual channel layer, (region A) of FIG. 1;

FIGS. 3A and 3B are graphs showing switching characteristics of a switching transistor TFT and a driving transistor TFT, respectively, in the driving device for a unit pixel of an organic light emitting display illustrated in FIG. 1;

FIGS. 4A through 4K are schematic drawings illustrating a method of manufacturing a driving device for a unit pixel of an OLED.

FIG. 5 is a schematic cross-sectional view of a unit pixel of an OLED.

FIG. 6 illustrates layout of main configuration of the unit pixel of an OLED as illustrated in FIG. 5; and

FIG. 7 is an equivalent circuit diagram showing a schematic structure of an OLED.

DETAILED DESCRIPTION OF THE INVENTION

The invention is described more fully hereinafter with reference to the accompanying drawings, in which embodiments of the invention are shown. This should not be construed as limiting the claims to the embodiments shown. Rather, these embodiments are provided to convey the scope of the invention to those skilled in the art. In the drawings, the size and relative sizes of elements and regions may be exaggerated for clarity.

It will be understood that when an element or layer is referred to as being “on”, “interposed”, “disposed”, or “between” another element or layer, it can be directly on, interposed, disposed, or between the other element or layer or intervening elements or layers can be present.

The terms “first,” “second,” and the like, “primary,” “secondary,” and the like, as used herein do not denote any order,

quantity, or importance, but rather are used to distinguish one element, region, component, layer, or section from another. The terms “front”, “back”, “bottom”, and/or “top” are used herein, unless otherwise noted, merely for convenience of description, and are not limited to any one position or spatial orientation.

The terms “a” and “an” do not denote a limitation of quantity, but rather denote the presence of at least one of the referenced item. The suffix “(s)” as used herein is intended to include both the singular and the plural of the term that it modifies, thereby comprising one or more of that term (e.g., the layer(s) includes one or more layers).

Reference throughout the specification to “one embodiment”, “another embodiment”, “an embodiment”, and so forth, means that a particular element (e.g., feature, structure, and/or characteristic) described in connection with the embodiment is included in at least one embodiment described herein, and may or may not be present in other embodiments. In addition, it is to be understood that the described elements may be combined in any suitable manner in the various embodiments.

The endpoints of all ranges directed to the same component or property are inclusive of the endpoint and independently combinable, e.g., ranges of “up to about 25 wt. %, or, more specifically, about 5 wt. % to about 20 wt. %,” is inclusive of the endpoints and all intermediate values of the ranges of “about 5 wt. % to about 25 wt. %,” etc. The modifier “about” used in connection with a quantity is inclusive of the stated value and has the meaning dictated by the context (e.g., includes the degree of error associated with measurement of the particular quantity).

Unless defined otherwise, technical and scientific terms used herein have the same meaning as is commonly understood by one of skill in the art to which this invention belongs.

FIG. 1 is a schematic cross-sectional view of a driving device for a unit pixel of an OLED. FIG. 2 is a cross-sectional scanning electronic microscope (SEM) photo of a first dual channel layer (region A) of FIG. 1. FIGS. 3A and 3B are graphs showing switching characteristics of a switching TFT **101** and a driving TFT **102**, respectively, in the driving device for a unit pixel of an OLED as illustrated in FIG. 1.

Referring to FIG. 1, a driving device for a unit pixel of an OLED includes a switching TFT **101** and a driving TFT **102**, which are in communication with each other, and are disposed on a substrate **10**.

The switching TFT **101** (T_{sw}) comprises a first dual channel layer **27a** having a first amorphous silicon layer **24a** and a first polycrystalline silicon layer **26a** which are adjacent to each other. A first gate electrode **20** is formed below the first dual channel layer **27a**. The switching TFT **101** is formed in a bottom gate structure, as illustrated in FIG. 1. A first insulating layer **22** is disposed between the first dual channel layer **27a** and the first gate electrode **20**. A first source region **40S** and a first drain region **40D** are formed at opposite ends of the first dual channel layer **27a**, respectively. The first source region **40S** can comprise an n-doped silicon (Si) layer **28a** and a first source electrode **30s**, which are disposed on one end of the first dual channel layer **27a**. The first drain region **40D** can comprise an n-doped Si layer **28a** and a first drain electrode **30d**, which are disposed on an opposite end of the first dual channel layer **27a**. The n-doped Si layer **28a** is a Si layer comprising an n-type dopant, such as As and P, and can be formed using a deposition process separate from that used to form the first dual channel layer **27a**.

The driving TFT **102** (T_{dr}) comprises a second dual channel layer **27b** having a second amorphous silicon layer **24b** and a second polycrystalline silicon layer **26b** which are

adjacent to each other. A second gate electrode **60** is formed above the second dual channel layer. The driving TFT **102** is formed in a top gate structure, as illustrated in FIG. 1. A second insulating layer **42** is disposed between the second dual channel layer **27b** and the second gate electrode **60**. A second source region **41S** and a second drain region **41D** are formed at opposite ends of the second dual channel layer **27b**, respectively. The second source region **41S** can comprise an n-doped Si layer **28b** and a second source electrode **31s**, which are disposed on an end of the second dual channel layer **27b**. The second drain region **41D** can comprise an n-doped Si layer **28b** and a second drain electrode **31d**, which are disposed on the opposite end of the second dual channel layer **27b**. The n-doped Si layer **28b** is a Si layer comprising an n-type dopant, such as As and P, and can be formed using a deposition process separate from deposition process used to deposit the second dual channel layer **27b**.

The first source region **40S** or the first drain region **40D** is in communication with the second gate electrode **60** via a first interconnection line **70** so that an electrical signal can be input to the driving TFT **102** from the switching TFT **101**.

In the structure of a driving device for a unit pixel of an OLED, the switching TFT **101** turns on/off a current supplied to the unit pixel, and the driving TFT **102** provides currents allocated to an OLED (not shown) formed in the unit pixel. Due to this role assignment, characteristics and specifications for the switching TFT **101** and the driving TFT **102** are different. For example, the switching TFT **101** can have a small leakage current and a large on/off ratio. On the other hand, it is desirable for the driving TFT **102** to have high mobility and reliability. In order to have these capabilities, the switching TFT **101** can be formed as an amorphous silicon TFT and the driving TFT **102** can be formed as a polycrystalline silicon TFT.

Hence, the driving device for a unit pixel of an OLED employs a dual channel layer having a dual layer structure in which an amorphous silicon (a-Si) layer and a polycrystalline silicon (poly-Si) layer are disposed, in each of the switching TFT **101** and the driving TFT **102**. The dual channel layer having the dual layer structure can perform functions of both an amorphous silicon channel and a polycrystalline silicon channel according to an arrangement relation between the dual channel layer and a gate electrode. Specifically, the switching TFT **101** is formed with a bottom gate structure in which the first gate electrode **20** is disposed below the first dual channel layer **27a**. Thus, the first amorphous silicon layer **24a** and the first gate electrode **20** are adjacent to each other and face each other. They are however, not in physical contact with one another. Using this bottom gate structure, the first amorphous silicon layer **24a** of the first dual channel layer **27a** can be selectively used as a channel. As a result, the switching TFT **101** can function as an amorphous silicon TFT having excellent switching characteristics.

The driving TFT **102** is formed in a top gate structure in which the second gate electrode **60** is disposed above the second dual channel layer **27b**. Thus, the second polycrystalline silicon layer **26b** and the second gate electrode **60** are adjacent to each other and face each other. They are however, not in physical contact with one another. From the top gate structure, only the second polycrystalline silicon layer **26b** of the second dual channel layer **27b** can be selectively used as a channel. As a result, the driving TFT **102** can function as a polycrystalline silicon TFT having high mobility.

Each of the first and second amorphous silicon layers **24a** and **24b** can be formed to a thickness of about 10 to about 500

angstroms (Å), and each of the first and second polycrystalline silicon layers **26a** and **26b** can be formed to a thickness of about 500 to about 3000 Å.

In one embodiment, the structure of the driving device for a unit pixel of an organic light emitting display has been improved so that channels in a switching TFT and a driving TFT can be simultaneously formed in one process. As a result, the driving device for a unit pixel of an OLED can be manufactured in a smaller number of processes and by simpler and easier processes compared with the manufacturing process used for other comparative commercially available devices.

FIGS. 4A through 4K are flowcharts illustrating a method of manufacturing a driving device for a unit pixel of an OLED.

In the method of manufacturing a driving device for a unit pixel of an OLED as illustrated in FIGS. 4A through 4K, each thin layer can be formed using thin layer deposition processes that are generally used in a semiconductor manufacturing process, for example, physical vapor deposition (PVD), chemical vapor deposition (CVD) or plasma enhanced chemical vapor deposition (PECVD).

Referring to FIGS. 4A through 4D, a gate metal, such as aluminum (Al) or molybdenum (Mo), is deposited on substrate **10** to a thickness of about 2000 to about 4000 Å and then is patterned, thereby forming a first gate electrode **20**. The substrate **10** can be an amorphous substrate or an insulating substrate. Thereafter, a first insulating layer **22** is formed on the entire surface of the substrate **10** using a material, such as SiO_x or SiN_x, so that the first gate electrode **20** can be disposed in the first insulating layer **22**. Next, an amorphous silicon layer **24** and a polycrystalline silicon layer **26** are disposed on the first insulating layer **22**. The amorphous silicon layer **24** can be formed to a thickness of about 10 to about 500 Å, and the polycrystalline silicon layer **26** can be formed to a thickness of about 500 to about 3000 Å. The amorphous silicon layer **24** and the polycrystalline silicon layer **26** can be consecutively formed in one deposition process. For example, after the substrate **10** on which the first insulating layer **22** is formed is installed into a PECVD chamber, the temperature of the PECVD chamber is kept at about 20° C. to about 500° C., and SiH₄ (gas) and H₂ (gas) are supplied into the PECVD chamber and are reacted for about 5 to about 60 minutes so that the amorphous silicon layer **24** and the polycrystalline silicon layer **26** can be consecutively formed on the first insulating layer **22**. The mixture ratio of SiH₄ (gas) and H₂ (gas), H₂ (gas) can be controlled to about 90 to about 99 volume (vol.) %. In this case, the pressure of the PECVD chamber can be controlled to about 30 to about 10000 milli-Torr, and the RF power of PECVD can be controlled to about 100 to about 1000 W.

Next, an n-doped Si layer **28** is formed on the polycrystalline silicon layer **26** to a thickness of about 200 to about 1000 Å. Here, arsenic (As) or phosphorus (P) is used as an n-dopant, and the n-dopant is supplied into the PECVD chamber together with SiH₄ (gas) and H₂ (gas). In an embodiment, the n-doped Si layer **28** is formed using a separate deposition process but is not limited to this. The n-doped Si layer **28** can be formed using other methods such as ion implantation.

In FIG. 4D, the n-doped Si layer **28**, the polycrystalline silicon layer **26**, and the amorphous silicon layer **24** are patterned, thereby forming first and second channel portions, separated from each other by a selected gap. Here, the first channel portion comprises a first dual channel layer **27a** having a first amorphous silicon layer **24a** and a first polycrystalline silicon layer **26a**, and an n-doped Si layer **28a** disposed on the first dual channel layer **27a**. The second channel portion comprises a second dual channel layer **27b** having a

second amorphous silicon layer **24b** and a second polycrystalline silicon layer **26b**, and an n-doped Si layer **28b** disposed on the second dual channel layer **27b**.

Referring to FIGS. 4E through 4G, an electrode layer **29**, covering the first and second channel portions, is formed on the first insulating layer **22** using metal, such as aluminum (Al) or molybdenum (Mo), to a thickness of about 2000 to about 4000 Å. The electrode layer is then patterned, thereby forming a first source electrode **30s** and a first drain electrode **30d** at opposite sides of the first channel portion, respectively, and forming a second source electrode **31s** and a second drain electrode **31d** at opposites sides of the second channel portion, respectively.

Next, a region of the n-doped Si layer **28a** connecting the first source electrode **30s** and the first drain electrode **30d** is selectively etched, thereby exposing a top surface of the first polycrystalline silicon layer **26a**. In this case, a process of etching the n-doped Si layer **28a** can be performed by using the first source electrode **30s** and the first drain electrode **30d** as a mask. A process of patterning the electrode layer **29** and a process of etching the n-doped Si layer **28a** so as to form the first source electrode **30s** and the first drain electrode **30d** can be performed simultaneously.

In addition, by using same method as the process of etching the n-doped Si layer **28a**, a region of the n-doped Si layer **28b** connecting the second source electrode **31a** and the second drain electrode **31d** is selectively etched, thereby exposing a top surface of the second polycrystalline silicon layer **26b**. In this case, a process of etching the n-doped Si layer **28b** can be performed by using the second source electrode **31s** and the second drain electrode **31d** as a mask. The process of patterning the electrode layer **29** and the process of etching the n-doped Si layer **28b** so as to form the second source electrode **31s** and the second drain electrode **31d** can be performed simultaneously. As a result of performing the process of FIG. 4G, a first source region **40S** and a first drain region **40D** can be formed at opposite sides of the first dual channel layer **27a**, respectively. Here, the first source region **40S** comprises an n-doped Si layer **28a** and a first source electrode **30s**, and the first drain region **40D** comprises an n-doped Si layer **28a** and a first drain electrode **30d**. Similarly, a second source region **41S** and a second drain region **41D** can be formed at opposite ends of the second dual channel layer **27b**, respectively. Here, the second source region **41S** comprises an n-doped Si layer **28b** and a second source electrode **31s**, and the second drain region **41D** comprises an n-doped Si layer **28b** and a second drain electrode **31d**.

Referring to FIG. 4H, a second insulating layer **42** is formed on the first insulating layer **22** using a material, such as silica (SiO_x) or silicon nitride (SiN_x), so that all of the first dual channel layer **27a**, the second dual channel layer **27b**, the first source region **40S**, the first drain region **40D**, the second source region **40D**, and the second drain region **41D** are disposed in the second insulating layer **42**. Next, a gate metal, such as Al or Mo, is deposited on the second insulating layer **42** to a thickness of about 2000 to about 4000 Å and then is patterned, thereby forming a second gate electrode **60**.

Referring to FIGS. 4I through 4K, the first drain electrode **30d** is in communication with the second gate electrode **60** via a first interconnection line **70** so that an electrical signal can be sent to the second gate electrode **60** from the first drain electrode **30d**. Specifically, a third insulating layer **62** is formed on the second insulating layer **42** using a material, such as SiO_x or SiN_x , so as to cover the second gate electrode **60**. Thereafter, partial regions of the third insulating layer **62** and the second insulating layer **42** are etched, thereby forming a first contact hole h_1 through which a partial region of the

first drain electrode **30d** is exposed and forming a second contact hole h_2 through which a partial region of the second gate electrode **60** is exposed. Next, a conductive material, such as Al or Mo, is filled in each of the first and second contact holes h_1 and h_2 , thereby forming the first interconnection line **70** that connects the first drain electrode **30d** and the second gate electrode **60**. Through the processes described herein, the driving device for a unit pixel of an OLED can be manufactured. Specifically, the structure of the driving device for a unit pixel of an OLED and a method of manufacturing the same have been improved so that channels in a switching TFT and a driving TFT can be simultaneously formed in one process. As a result, the driving device for a unit pixel of an OLED can be manufactured in a smaller number of simpler and easier processes.

FIG. 5 is a schematic cross-sectional view of a unit pixel of an OLED. FIG. 6 illustrates layout of main configuration of the unit pixel of an OLED as illustrated in FIG. 5, and FIG. 7 is an equivalent circuit diagram showing a schematic structure of an OLED.

Referring to FIGS. 5 through 7, the OLED is disposed on a substrate **10** in a matrix shape and comprises a plurality of unit pixels (P). Each of the unit pixels (P) comprises a driving device for a unit pixel having a pair of a switching TFT **101** and a driving TFT **102**, which are in electrical communication with each other, and an OLED **100** for a unit pixel.

Referring to FIG. 6, the OLED **100** for a unit pixel comprises a first electrode **90**, an organic light emitting layer **96**, and a second electrode **98**. The first electrode can be formed of a transparent conductive material, such as indium tin oxide (ITO), and serves as an anode. Materials used in forming the organic light emitting layer **96** and methods of manufacturing the same are known. The second electrode **98** can be formed of a conductive material, such as Al or silver (Ag), and serves as a cathode. The first electrode **90** of the OLED **100** is in communication with a second drain electrode **31d** of the driving TFT **102** via a second interconnection line **80** which may be formed of a conductive material, such as Al or Mo.

In view of a method of manufacturing the OLED **100** for a unit pixel, in succession to the process of FIG. 4K, a fourth insulating layer **72** is formed on the entire surface of the third insulating layer **62** using a material, such as SiO_x or SiN_x , so as to be disposed upon the first interconnection line **70**. Thereafter, the second, third, and fourth insulating layers **42**, **62**, and **72** are sequentially etched, thereby forming a third contact hole h_3 through which a partial region of the second drain electrode **31d** is exposed. The interconnect line **80** is disposed in the hole h_3 via conventional deposition method, such as sputtering, thermal evaporation or ion beam evaporation. Next, the first electrode **90** is formed on the fourth insulating layer **72** using a transparent conductive material, such as ITO, so as to contact the second interconnection line **80**. Next, a fifth insulating layer **92** is formed on the entire surface of the fourth insulating layer **72** using a material, such as SiO_x or SiN_x , so as to cover the first electrode **90**. Next, a partial region of the fifth insulating layer **92** is etched, thereby forming a fourth contact hole h_4 through which the first electrode **90** is exposed. Next, the organic light-emitting layer **96** is formed on the fifth insulating layer **92** so as to cover the first electrode **90**, and a second electrode **98** is formed on the organic light-emitting layer **96** using a conductive material, such as Al or Ag.

Referring once again to FIGS. 5, 6 and 7, in the OLED, a first source electrode **30s** of a switching TFT **101** is electrically connected to a data line (DL) to which a data signal is input from a horizontal driving circuit (as can be seen in the FIG. 5), for example. As such, the data line DL can be electrically connected to a second gate electrode **60** of a driving TFT **102** through the first source electrode **30s** and the first drain electrode **30d** of the switching TFT **101**. A first gate electrode **20** of the switching TFT **101** is electrically con-

nected to a select line (SL) to which a select signal is input from a vertical scanning circuit. A second source electrode **31s** of the driving TFT **102** is electrically connected to a power line (PL) to which a driving power is supplied from a power circuit. As such, the power line PL can be connected to each OLED **100** for a unit pixel through the second source electrode **31s** and the second drain electrode **31d** of the driving TFT **102**.

The data line DL and the select line SL are disposed to cross perpendicular to each other, and a unit pixel P is defined by a crossing data line DL and a crossing select line SL. Meanwhile, a portion extending from the first drain electrode **30d** of the switching TFT **101** and the second gate electrode **60** of the driving TFT **102**, which are in communication with each other, and the power line PL can constitute a storage capacitor C_s of FIG. 7.

In an embodiment, the driving device for a unit pixel of an OLED comprises a switching TFT and a driving TFT that can be manufactured by a series of consecutive processes. Specifically, the structure of the driving device for a unit pixel of an OLED and the method of manufacturing the same have been improved so that channels in a switching TFT and a driving TFT can be simultaneously formed in one process. As a result, the driving device for a unit pixel of an OLED according to the present invention can be manufactured in a smaller number of processes and in simpler and easier processes compared to the prior art. Accordingly, defect rates during manufacturing can be reduced, and manufacturing yields can be increased, thereby, manufacturing reproducibility and reliability can be improved.

While the subject matter of the claims has been shown and described with reference to exemplary embodiments thereof, it will be understood by those of ordinary skill in the art that various changes in form and details can be made therein without departing from the spirit and scope of the following claims.

What is claimed is:

1. A driving device for a unit pixel of an organic light emitting display, the driving device for a unit pixel comprising:

a switching thin film transistor (TFT) and a driving TFT, which are disposed on a substrate and in communication with each other;

wherein the switching TFT comprises a first dual channel layer and a first gate electrode, the first dual channel layer comprising a first amorphous semiconducting silicon layer and the first polycrystalline silicon layer, and a first gate electrode is disposed below the first dual channel layer;

wherein the driving TFT comprises a second dual channel layer and a second gate electrode, the second dual channel layer comprising a second amorphous semiconducting silicon layer and a second polycrystalline silicon layer, and the second gate electrode is disposed above the second dual channel layer, and wherein a first insulating layer is disposed between the first dual channel layer and the first gate electrode and a second insulating layer is disposed between the second dual channel layer and the second gate electrode.

2. The driving device of claim 1, wherein the first and second amorphous silicon layers are formed to a thickness of about 10 to about 500 Å.

3. The driving device of claim 1, wherein the first and second crystalline silicon layers are formed to a thickness of about 500 to about 3000 Å.

4. The driving device of claim 1, wherein a first source region and a first drain region are disposed at opposite sides of the first dual channel layer.

5. The driving device of claim 4, wherein the first source region comprises an n-doped silicon layer and a first source electrode, which are disposed on an end of the first dual channel layer.

6. The driving device of claim 4, wherein the first drain region comprises an n-doped silicon layer and a first drain electrode, which are disposed on an a side of the first dual channel layer opposite the first source region.

7. The driving device of claim 4, wherein the first source region or the first drain region is in electrical communication with the switching TFT.

8. The driving device of claim 1, wherein a second source region and a second drain region are disposed at opposites sides of the second dual channel layer.

9. The driving device of claim 8, wherein a second source region comprises an n-doped silicon layer and a second source electrode.

10. The driving device of claim 8, wherein the second drain region comprises an n-doped Si layer and a second drain electrode, which are disposed on a side of the second dual channel layer opposed to the second source region.

11. An organic light emitting display comprising: a plurality of unit pixels disposed on a substrate in a matrix shape, wherein each of the unit pixels comprises:

a driving device for a unit pixel further comprising a switching TFT and a driving TFT that are in electrical communication with each other; and

an organic light emitting device for a unit pixel;

wherein the switching TFT comprises a first dual channel layer and a first gate electrode, the first dual channel layer having a first amorphous semiconducting silicon layer and a first polycrystalline silicon layer, and the first gate electrode is disposed below the first dual channel layer;

wherein the driving TFT comprises a second dual channel layer and a second gate electrode, the second dual channel layer having a second amorphous semiconducting silicon layer and a second polycrystalline silicon layer, and a second gate electrode is disposed above the second dual channel layer, and wherein a first insulating layer is disposed between the first dual channel layer and the first gate electrode and a second insulating layer is disposed between the second dual channel layer and the second gate electrode.

12. The organic light emitting display of claim 11, wherein the first and second amorphous silicon layers are formed to a thickness of about 10 to about 500 Å.

13. The organic light emitting display of claim 11, wherein the first and second crystalline silicon layers are formed to a thickness of about 500 to about 3000 Å.

14. The organic light emitting display of claim 11, wherein a first source region and a first drain region are formed at opposite sides of the first dual channel layer.

15. The organic light emitting display of claim 14, wherein the first source region or the first drain region is in communication with the second gate electrode so that the driving TFT and the switching TFT are in electrical communication with each other.

16. The organic light emitting display of claim 11, wherein a second source region and a second drain region are disposed at opposite end of the second dual channel layer.

* * * * *

专利名称(译)	用于有机发光显示器的单位像素的驱动装置及其制造方法		
公开(公告)号	US8405161	公开(公告)日	2013-03-26
申请号	US11/877308	申请日	2007-10-23
[标]申请(专利权)人(译)	三星电子株式会社		
申请(专利权)人(译)	SAMSUNG ELECTRONICS CO. , LTD.		
当前申请(专利权)人(译)	SAMSUNG ELECTRONICS CO. , LTD.		
[标]发明人	PARK KYUNG BAE KWON JANG YEON LEE SANG YOON JUNG JI SIM		
发明人	PARK, KYUNG-BAE KWON, JANG-YEON LEE, SANG-YOON JUNG, JI-SIM		
IPC分类号	H01L27/088		
CPC分类号	H01L27/1214 H01L27/1251 H01L29/78696 H01L29/04 H01L27/3244 H01L27/1229		
代理机构(译)	康托科尔伯恩LLP		
审查员(译)	WEISS , 霍华德		
优先权	1020060116057 2006-11-22 KR		
其他公开文献	US20080116457A1		
外部链接	Espacenet USPTO		

摘要(译)

提供一种用于具有改进结构的有机发光显示器的单位像素的驱动装置及其制造方法。

